

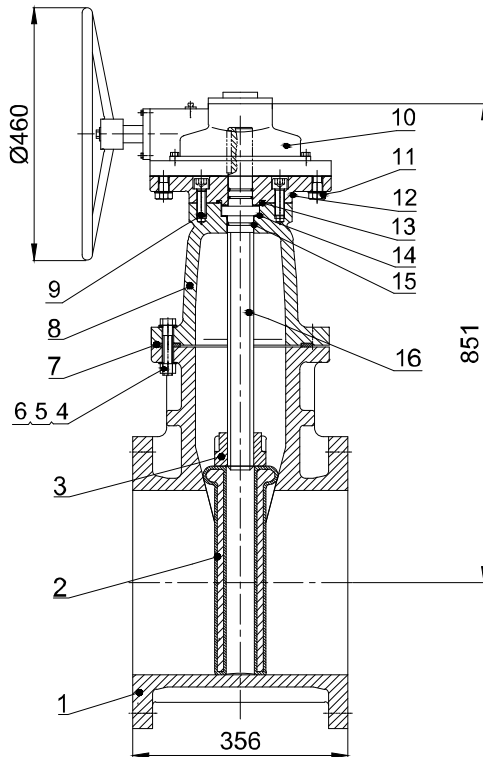

Terminal City Iron Works Ltd.



Item	Part Name	Material	ASTM Spec.
1	Body	Ductile Iron	A536 65-45-12
2	Wedge	EPDM Encapsulated Ductile Iron	A536 65-45-12
3	Stem Nut	Bronze	B148 C95200
4	Bolt	Stainless Steel	F593 Type 304SS
5	Nut	Stainless Steel	A276 Type 316SS
6	Washer	Stainless Steel	A276 Type 316SS
7	Gasket	Rubber	D2000 EPDM
8	Bonnet	Ductile Iron	A536 65-45-12
9	Screw	Stainless Steel	F593 Type 304SS
10	Bevel Gear	Assembly	Gear Ratio 3:1
11	Bolt	Stainless Steel	F593 Type 304SS
12	Gland	Ductile Iron	A536 65-45-12
13	O-Ring	Rubber	D2000 NBR
14	Washer	Brass	B124 C37700
15	O-Ring	Rubber	D2000 NBR
16	Stem	Stainless Steel	A276 Type 304SS



Terminal City Iron Works Ltd.

AWWA C509 Assembly Drawing NRS Gate Valve

DRG NO.

3500 Series NRS FL x FL (12")

REV

A

FUSION BONDED EPOXY-NSF 61-AWWA C550