

TERMINAL CITY STEEL GATE VALVE CLASS 150

RATED WORKING PRESSURE 285 PSI / 1964 kPa

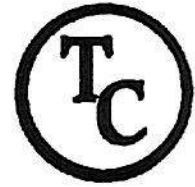

MANUFACTURING STANDARDS	
DESIGN	ASME B16.34
FLANGE	ASME B16.5 F.F.
TESTING	ISO 5208 / MSS SP-61

CLASS 150 TEST PRESSURE	
HYDROSTATIC	
BODY	SEAT / BACK SEAT
570 PSI	285 PSI
3930 kPa	1964 kPa
40 Kg / cm ²	20 Kg / cm ²

No.	PART	MATERIAL
1	Body	ASTM A216 WCB
2	Wedge Rings	ASTM B584 Bronze
3	Body Rings	ASTM B584 Bronze
4	Wedge	ASTM A216 WCB
5	Wedge Nut	ASTM B584 Bronze
6	Body Gasket	ASTM F104
7	Body Bolt Nuts	ASTM A194 plated
8	Body Bolts	ASTM A449 plated
9	Bonnet	ASTM A216WCB
10	Spindle	ASTM B584 C87600
11	Gland Gasket	ASTM F104
12	Gland O Rings	ASTM D2000 buna
13	Gland Stud Nuts	ASTM A194 plated
14	Gland Studs	ASTM A276 stainless
15	Gland	ASTM A126 B
16	Operating Nut	ASTM A126 B
17	Cotter Pin	Carbon Steel
18	Name Plate	Brass

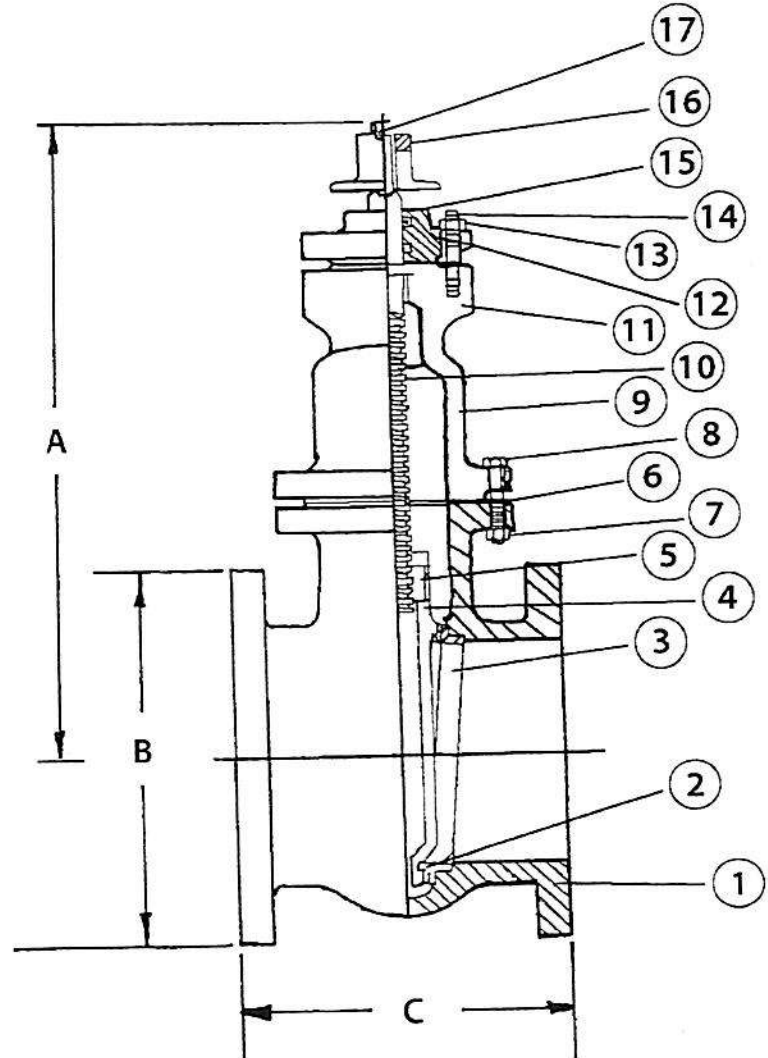

These TC IBBM Gate Valves are manufactured in British Columbia to AWWA C500 and comply to NSF/ANSI 61 & NSF/ANSI 372

SIZE		DIMENSIONS (inch / mm)					
inch / mm		A		B		C	
4	100	15	381	9	229	9	229
6	150	19	483	11	279	10 1/2	267
8	200	23	582	13 1/2	343	11 1/2	292
10	250	28	711	16	406	13	330
12	300	32	813	19	483	14	356

Turns to Open
14
20
26
32
38